



TECHOCAT WORK SERIES

CGB10 | CGB18

CGB10 | CGB18

WORK SERIES

CGB10 COMPATIBLE WITH: VL-GB4

CGB18 COMPATIBLE WITH: VL-GB4

WORK SERIES





VL-CGB10





VL-CGB18

CGB10 EXAMPLE

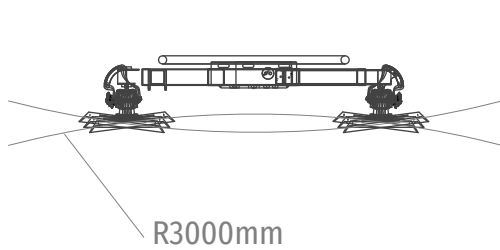
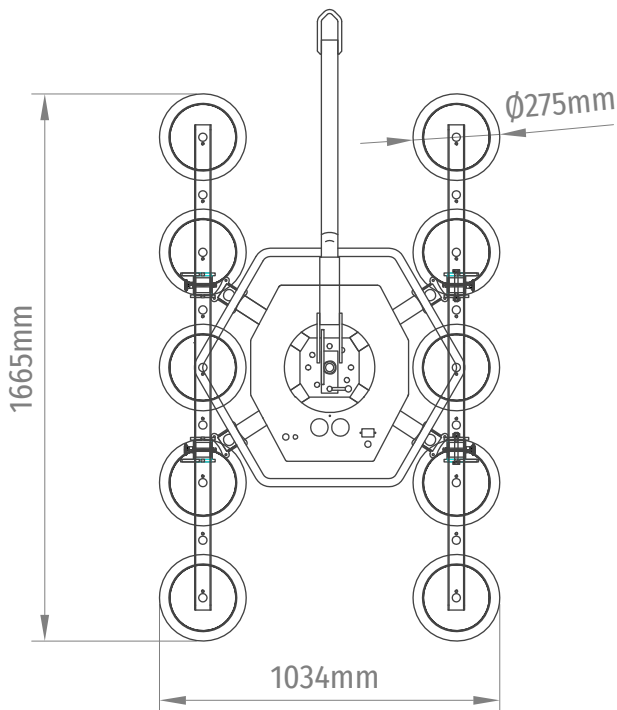
 500 kg
 OK



CGB18 EXAMPLE

 270 kg
 OK

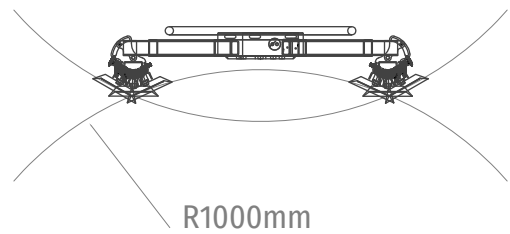
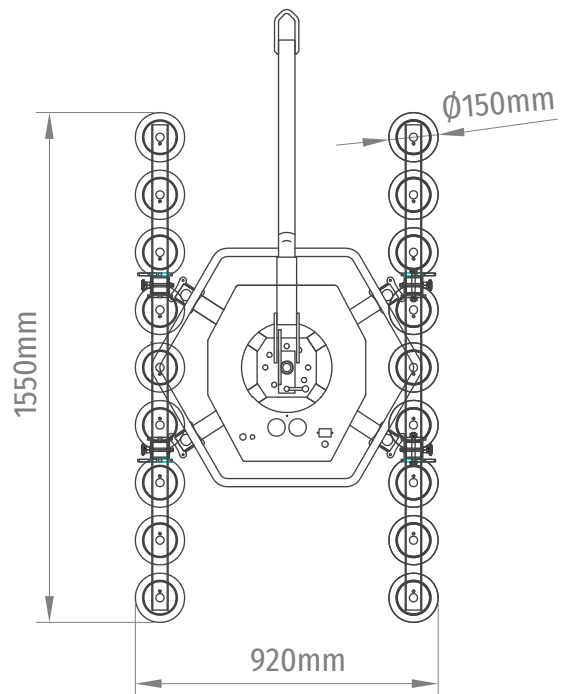

PICTOGRAMS



ELECTRICAL POWER



NOMINAL ELECTRIC POWER



ENERGY AUTONOMY BY BATTERIES



PNEUMATIC SUPPLY



MAXIMUM LOAD CAPACITY



MAXIMUM LOAD CAPACITY ACCORDING EN-13155



TILTING EQUIPMENT



MANUALLY TILTING EQUIPMENT



PNEUMATIC TILTING EQUIPMENT



MOTORIZED TILTING EQUIPMENT



HYDRAULIC TILTING EQUIPMENT



ROTATION EQUIPMENT



MANUAL ROTATION EQUIPMENT



PNEUMATIC ROTATION EQUIPMENT



MOTORIZED ROTATION EQUIPMENT



HYDRAULIC ROTATION EQUIPMENT



EQUIPMENT WEIGHT



VACUUM SYSTEM AIR FLOW



PUSHBUTTON CABLE LENGTH



WIRELESS PUSHBUTTON



LOAD CAPACITY ACCORDING EN-13155



EQUIPMENT SUPPORT SYSTEM



LIFTING CRANE USABLE ROTATION