



TECHOCAT WORK SERIES

VL-GB4 | VL-GB4+4

VL-GB4 | VL-GB4+4

WORK SERIES

VL-GB4



300 kg



45 kg

WORK SERIES



VL-GB4+4







600 kg



65 kg

 OK
 90° - 180° - 270° - 360°
 0° - 60° - 90°
 83 L/min

 80 W
 BATTERY CHARGE 220-240V AC 50-60 HZ
 OK - BATTERY 12V - Running period 20h aprox
 OK

VL-GB4

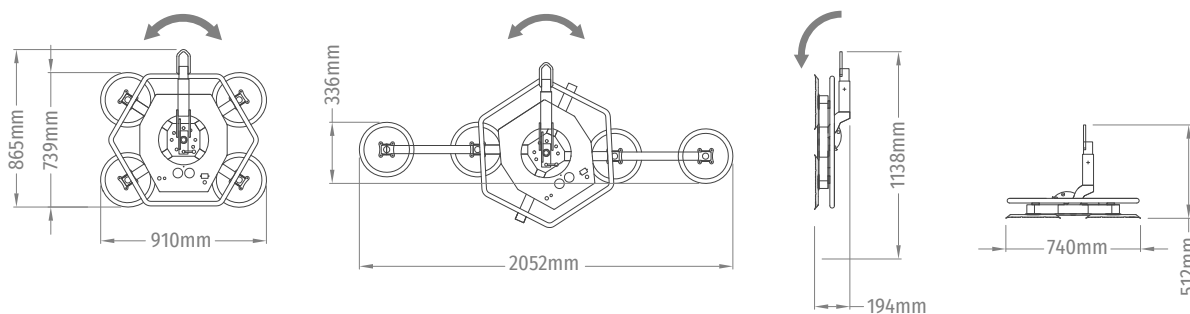

VL-GB4+4

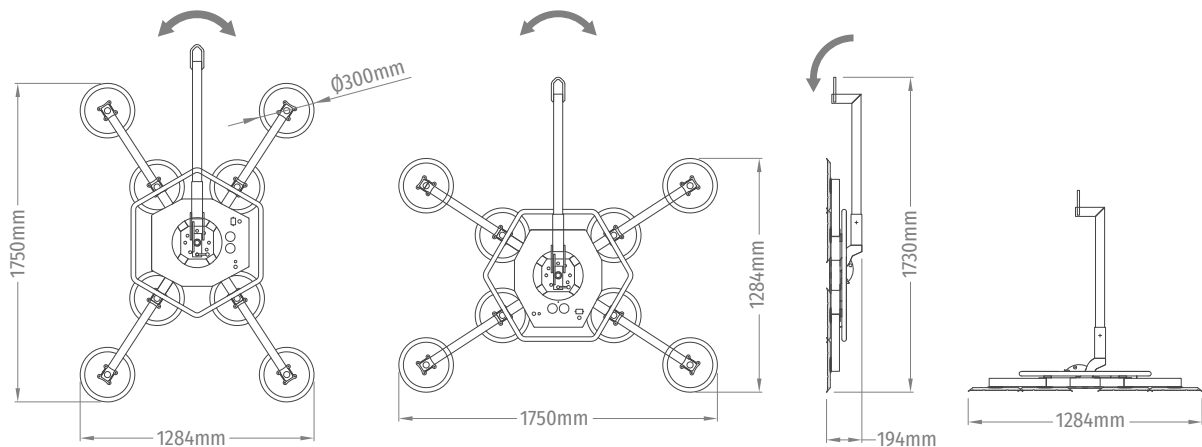

INCLUDED

- SUPPORT WITH WHEELS
- METAL HANGING EXTENSION 2 SIZES

OPTIONAL

- **CM-VL** METAL BOX
- **FU-P** COVERS
- HYDRAULIC PISTON
- A. CURVED ARM 9+9 CUPS Ø125 (270KG)
- B. CURVED ARM 5+5 CUPS Ø275 (500KG)

PICTOGRAMS



ELECTRICAL POWER



NOMINAL ELECTRIC POWER



ENERGY AUTONOMY BY BATTERIES



PNEUMATIC SUPPLY



MAXIMUM LOAD CAPACITY



MAXIMUM LOAD CAPACITY ACCORDING EN-13155



TILTING EQUIPMENT



MANUALLY TILTING EQUIPMENT



PNEUMATIC TILTING EQUIPMENT



MOTORIZED TILTING EQUIPMENT



HYDRAULIC TILTING EQUIPMENT



ROTATION EQUIPMENT



MANUAL ROTATION EQUIPMENT



PNEUMATIC ROTATION EQUIPMENT



MOTORIZED ROTATION EQUIPMENT



HYDRAULIC ROTATION EQUIPMENT



EQUIPMENT WEIGHT



VACUUM SYSTEM AIR FLOW



PUSHBUTTON CABLE LENGTH



WIRELESS PUSHBUTTON



LOAD CAPACITY ACCORDING EN-13155



EQUIPMENT SUPPORT SYSTEM



LIFTING CRANE USABLE ROTATION